

SEC-ASD 531

Aspirating Smoke Detector

As of production version 151015 and FW version 01.00.08

The SEC-ASD 531 aspirating smoke detector has the task of continuously taking air samples via a sampling pipe tube network from a monitored area and feeding the samples to a smoke sensor.

The SEC-ASD 531 consists of the detector housing and a sampling pipe tube network. The sampling pipe has several sampling holes whose size is such that each hole extracts the same amount of air. The sampling pipe may be I-, U-, T-, H-, or E-shaped. The sampling pipe is symmetrically designed in principle. Asymmetrical sampling pipe tube networks can also be implemented with the help of the "ASD PipeFlow" calculation software.



Fig. 1 SEC-ASD 531

Description

Integrated in the detector housing is a fan which, in conjunction with the sampling pipe, ensures an uninterrupted supply of air to the detector housing. Airflow monitoring detects any pipe blockages and pipe breakages in the sampling pipe.

The SEC-ASD 531 aspirating smoke detector is part of the SEC-ASD 535 product range and is available in a version for 1 sampling tube and 1 smoke sensor without smoke level indicator.

The **SSD 31** smoke sensor is used in the SEC-ASD 531. It has an alarm sensitivity range of 0.02%/m to 10%/m.

The SEC-ASD 531 aspirating smoke detector has two slots for additional modules. The following modules can be fitted:

- XLM 35 eXtended Line Module
- RIM 36 Relay Interface Module with 5 relays

The SEC-ASD 531 can be connected to a superordinate FACP by means of potential-free change-over contacts.

With the installation of an **XLM 35**, the SEC-ASD 531 can be ideally connected via the addressable loop to the SecuriFire and Integral fire alarm systems.

The **RIM 36** is available as a further installation option. This module enables the availability of all three pre-signal levels as well as the states of the smoke sensor and the sampling pipe.

The SEC-ASD 531 aspirating smoke detector can be used for:

- **Equipment monitoring:** EDP systems, electrical distributors, switch cabinets, etc.
- **Space monitoring:** EDP rooms, ultra-clean rooms, warehouses, hollow floors, protection of cultural assets, transformer stations, prison cells, etc.

The SEC-ASD 531 can also be deployed in areas where normally conventional point detectors are used. Local regulations and provisions must be observed from case to case.

The response behaviour of the SEC-ASD 531 has been tested in compliance with EN 54-20, Class A, B and C.



When setting up ASD 531 fire alarm systems, the information and specifications in "**Technical Description ASD 531**" must be observed and adhered to. This includes among others:

- | | |
|------------------------|-----------|
| • General | Section 1 |
| • Planning | Section 4 |
| • Mounting | Section 5 |
| • Installation | Section 6 |
| • Commissioning | Section 7 |
| • Operation | Section 8 |

Opening the detector housing



Press the rotary snap locks down **firmly** with a screwdriver (at least No. 5) toward the housing base and then **turn 90°** to open them. The position of the lock slit shows the current status:

- angled approx. 45° toward detector housing corner = closed;
- angled approx. 45° toward detector housing edge = open.

In either position the rotary snap locks **must** snap into place.

Connection

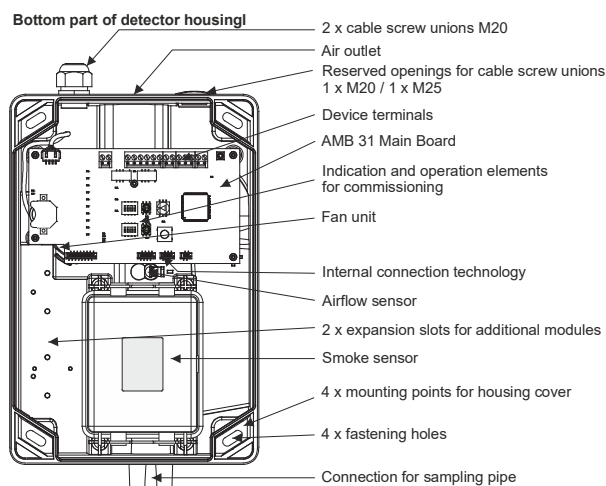

Fig. 2 Inside view of the SEC-ASD 531

Device connections on the AMB 31

The electrical connection is by means of plug-in terminals.

Terminal	Signal	
1	+14 to +30 VDC ①	Main power supply line
2	0 V	
3	+14 to +30 VDC ①	Redundant power supply line
4	0 V	
5	+ supply (for OC consumers)	
6	Output Fault, OC (all events)	
7	Output Alarm, OC	
8	Rel. 1 "(NO)"	Fault
9	Rel. 1 "(NC)"	Contact (terminal 8/10)
10	Rel. 1 "COM"	closed in idle state
11	Rel. 2 "NO"	Alarm
12	Rel. 2 "NC"	
13	Rel. 2 "COM"	
14	Input Reset external +	Opto-isolator input reset
15	Input Reset external -	

XLM 35, RIM 36 terminal assignment

The terminal assignments of the XLM 35 and RIM 35 can be found in the corresponding data sheets T 140 088 (XLM 35) and T 140 364 (RIM 36).

Wiring principle



Examples of and information on the wiring principle can be found in the Technical Description ASD 531, T 140 416, Sec. 6.

Using the smoke sensor

The SEC-ASD 531 ships with the smoke sensor already fitted. The smoke sensor has to be removed from the detector housing for the installation of the ASD (release the two lock clamps); however it should be left inside its protective packaging until the definitive commissioning. The definitive installation is carried out as described below, see Fig. 3.



- Always leave the smoke sensor inside its protective packaging until it is ready to be installed definitively in the detector housing.
- Depending on the situation – (e.g. if there is a long time between mounting and commissioning or if the environment is extremely dusty (construction work) – only remove the smoke sensor from its protective packaging and insert it definitively in the detector housing when commissioning the SEC-ASD 531.
- Before installing the smoke sensor check that the insect protection screens are properly fitted to the smoke sensor chamber at the air inlet and outlet.
- The smoke sensor chamber must be absolutely free of any dirt and/or dust. Remove any residue resulting from mounting the detector housing.

Check the installation position when installing the smoke sensor. The connector plug of the smoke sensor must be face away from the slots of the additional modules. The anti-twist rib on the smoke sensor case prevents an incorrect installation position.

The smoke sensor is secured inside the ASD housing using the two lock clamps. Connect the ribbon cable supplied with the smoke sensor to the smoke sensor (large ribbon cable connector) and to the AMB 31 main board (small ribbon cable connector).

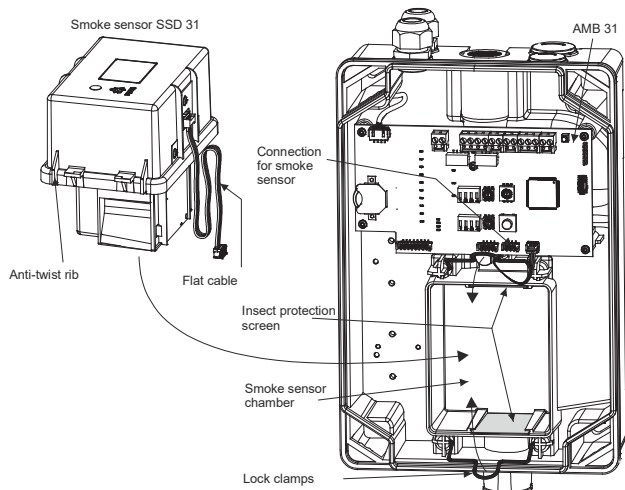

Fig. 3 Using the smoke sensor

Displays on the control unit

Several LEDs on the control unit indicate the current status of the SEC-ASD 531.

Function / state	Operation	Alarm	Fault	Det. dusty / dirty
	green	red	yellow	yellow
System Off (no voltage)				
System inactive (reset external)	On		½ T	
Smoke sensor Off (from FACP)	On		½ T	
Quiescent state	On			
Pipe blockage/breakage, delay running ①	On		1 T	
Pipe blockage/breakage, fault triggered	On		On	
Fan tacho signal missing	On		On	
Fault triggered	On		On	
Pre-signal 1	On	2 T		
Pre-signal 2	On	1 T		
Pre-signal 3	On	½ T		
Alarm	On	On		
Smoke sensor dusty	On			1 T
Smoke sensor+ dirty	On			½ T
Smoke sensor faulty	On			On



① No fault triggered (triggers only after delay time has expired → "Fault" continuously lit).

T = flashing display; ½ s cycle / 1 s cycle / 2 s cycle

Indicators on the AMB 31 main board

Various auxiliary LEDs are on the AMB 31 and have the following meaning:

- LED "Class" and "Holes" flash = invalid constellation of rotary switches "Class" and "Holes";
- LED "Mode" = various functions;
- LED "WDog" = watchdog indicator;
- LED CardOk = SD memory card present
- LED Com = communication with the SD memory card.

Programming

The SEC-ASD 531 has several switch positions that are configured with permanently assigned parameters:

- System limits according to EN 54-20, Class A to C, without using "ASD PipeFlow", positions **A/1** to **C/C**;
- System limits for saving the settings after using "ASD PipeFlow", positions **1/1** to **3/F**.

Switch positions of rotary switch "Mode"

Pos.	Purpose
0	Initial reset
1	Operation position
2	Isolate device
3	Test trigger fault
4	Test trigger pre-signal
5	Test trigger alarm
6	Log off optional module
7	Device inactive
8 – 16	Reserve



The table lists only the available switch positions. For information about the input procedure please refer to Technical Description T 140 416, Sec. 8.3.

System limits without ASD PipeFlow calculation

The system limits apply to the planning without using the ASD PipeFlow calculation software. There are two areas, with the following meaning:

- **Detector sensitivity**
Rotary switch "Class", switch positions **A** to **C**;
Rotary switch "Holes", switch positions **1** to **C**;
- **Air flow tolerance and delay time**
DIP switch "Airflow", switch positions **1** to **4**.

Detector sensitivity

The desired alarm class according to EN 54-20 is set on the "Class" rotary switch. The switch position corresponds to the class (switch position **A** = response grade **A**).

The total number of sampling holes is set on the "Holes" rotary switch (**A** = 10, **B** = 11, **C** = 12).

Air flow tolerance and delay time

The air flow tolerance and delay time are set on the "Airflow" DIP switch:

Switch 1	Switch 2	Air flow tolerance
OFF	OFF	±20% ①
OFF	ON	±30%
ON	OFF	±50%
ON	ON	±10%

Switch 3	Switch 4	Delay time
OFF	OFF	300 s (5 min) ①
OFF	ON	10 min
ON	OFF	20 min
ON	ON	10 s (test position) ②



- ① For a normative system the setting **±20% / 300 s** is required. Other values are **not** EN tested and may be used only after consulting with the manufacturer.
- ② This setting may be used only for test purposes; it is not permitted in normal operation.

Shape	Length from ASD to the last T-piece/cross	Max. length from ASD to farthest sampling hole	Number of sampling holes per sampling branch	Max. overall length of the sampling pipe
I	---	30 m	1 – 7	30 m
U / T	1 – 10 m	30 m	1 – 6	55 m
H	1 – 10 m	20 m	1 – 3	55 m
E	1 – 10 m	20 m	1 – 4	55 m

Sampling holes for planning with ASD PipeFlow calculation

The tables below show the corresponding hole diameters for the numbers in Fig. 4 depending on the number of sampling holes per sampling branch.

1 to 7 = sampling hole number

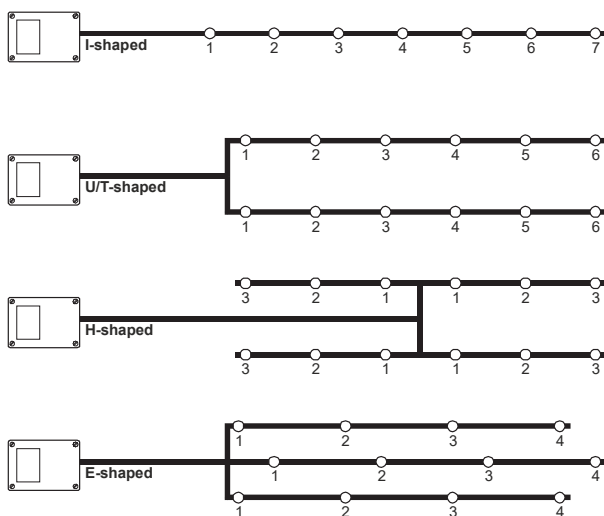

Fig. 4 Size of sampling holes

Number of sampling holes in the sampling branch	Hole diameter in mm for the sampling hole number from the ASD						
	1	2	3	4	5	6	7
1	7.0						
2	5.5	7.0					
3	5.0	5.5	7.0				
4	4.5	4.5	5.5	7.0			
5	4.0	4.5	5.0	5.0	6.5		
6	3.5	4.0	3.5	3.5	4.0	5.5	
7	3.5	3.5	3.5	3.5	4.0	4.0	5.5

Number of sampling holes per sampling branch	Hole diameter in mm for the sampling hole number from the ASD					
	1	2	3	4	5	6
1	7.0					
2	5.0	6.5				
3	4.5	5.0	7.0			
4	3.5	4.0	4.0	6.5		
5	3.0	3.0	3.0	3.0	5.5	
6	3.0	3.0	3.0	3.0	3.0	5.5

Number of sampling holes per sampling branch	Hole diameter in mm for the sampling hole number from the ASD		
	1	2	3
1	7.0		
2	3.5	6.5	
3	2.5	2.5	6.5

Number of sampling holes per sampling branch	Hole diameter in mm for the sampling hole number from the ASD			
	1	2	3	4
1	7.0			
2	4.5	7.0		
3	3.0	3.0	6.0	
4	2.5	2.5	2.5	6.0

Relay self-holding:

A self-holding function for various signals can be switched on on the "Relay" DIP switch.

Signal	Switch position ③	Default Setting	Range
• Alarm	1	On	On / Off
• Fault ①	2	On	On / Off
• Pre-signal ②	3	Off	Off / On



- ① Also has an effect on relays 4 + 5 on a built-in RIM 36.
- ② Has an effect only on a built-in RIM 36 (relay 1 – 3)
- ③ Switch position 4 has no function.

RIM 36 relay assignment:

Relay	Signal
Relay 1	Pre-signal 1 smoke sensor
Relay 2	Pre-signal 2 smoke sensor
Relay 3	Pre-signal 3 smoke sensor
Relay 4	Smoke sensor dirt Smoke sensor dust Smoke sensor fault
Relay 5	Sampling tube blockage Sampling tube interruption Fan fault

Commissioning

When commissioning the SEC-ASD 531, it is necessary to perform an initial reset to automatically adjusting the airflow monitoring on the connected sampling pipe.

If the SEC-ASD 531 is operated without "ASD PipeFlow" calculation, the commissioning can be carried out directly using the "BasiConfig" process.

In projects in which the "ASD PipeFlow" calculation software was used, the switch settings "1/1" to "3/F" are to be applied.

Starting up



Before the SEC-ASD 531 is switched on, make sure all the precautions required for its operation have been taken (see also T 140 416, Sec. 7.1).

- Sampling pipe correctly laid and connected;
- Smoke sensor removed from protective packaging, built in and connected;
- Isolation strip on the lithium battery (AMB 31)
- removed.

Startup sequence and procedure:

1. Switch on supply voltage (FACP); the next procedure can be carried out while the fan is ramping up to its definitive speed (takes about 100 s). **The system is immediately armed for alarm.**
2. "BasiConfig": Set the required response grade and the number of sampling holes (e.g. "B/6") → see also "Re-programming".
- or:
Select corresponding "ASD Pipeflow": values (Technical Description ASD 531, T 140 416, Sec. 4.3.1). Set rotary switch.
3. Following a **minimum waiting time of 2 min** after switching on, an initial reset must be performed (possible only via AMB 31) → see "Initial reset".
4. The SEC-ASD 531 is now ready for operation.

Re-programming

Example: Response grade B, sampling holes 6, airflow tolerance / delay time $\pm 30\%$ / 600 s ①.

Measure	Indicator ②	Procedure Remark
1. Turn rotary switch "Class" to position "B"	--	Set response grade B
2. Turn rotary switch "Holes" to position "6"	--	Set 6 sampling holes
3. Set DIP switch "Air-flow": Positions "1" and "3" on "OFF"; Positions "2" and "4" on "ON";	--	Set airflow tolerance / delay time $\pm 30\%$ / 600 s ①



① For normative systems the setting $\pm 20\%$ / 300 s is required. Other values are **not** EN tested and may be used only after consulting with the manufacturer.



② The "Class" and "Holes" LEDs begin to flash after a delay time when there is an invalid entry (e.g. Class A with 10 sampling holes).

Initial reset

Measure	Indicator	Procedure Remark
Before performing an initial reset after switching on the SEC-ASD 531, a waiting time of at least 2 min must be observed.		
1. Turn rotary switch "Mode" to position "0"	--	• Switch position initial reset
2. Press key "Set/Res"	--	• Initial reset in progress
3. Wait	Both middle LEDs of the airflow indicator are lit	• Initial reset completed
4. Turn rotary switch "Mode" to position "1"	--	• Operation switch position
5. Press key "Set/Res"	--	• Operating mode running

Measurements / commissioning protocol

Carry out the following measurements:

- Measure voltage at terminals 1 (+), 2 (-) (also terminals 3 and 4 if redundant supply) → target value = 17.6 to 27.6 VDC
- Airflow value in switch positions **V** (see Technical Description, T 140 416, Sec. 7.6.1).

The commissioning protocol is like a personal history of the SEC-ASD 531 and should therefore be filled out conscientiously and completely and stored in the SEC-ASD 531. If required, a copy can be made and stored in the system dossier.

Checking fault and alarm release

Test	Procedure	Action
	Block or switch off fire incident control and remote alerting on the superordinate FACP.	
Check airflow monitoring	Tape over the sampling holes (adhesive tape); the number depends on the pipe configuration.	<ul style="list-style-type: none"> As soon as the resulting change in the airflow is exceeded by $\pm 20\%$, the "Fault" LED begins to flash. Once the LS-Ü delay (300 s) has elapsed, the ASD triggers a fault → fault on FACP ①.
Check alarm release	Impose smoke at the maintenance sampling hole or sampling hole.	<ul style="list-style-type: none"> ASD triggers an alarm → alarm on FACP; check for correct alarm transmission (zone/range release) on the FACP ①. Any pre-signals will also release.

① Reset the SEC-ASD 531 between each check (please note: reset-ting the ASD does not reset the FACP).

Article numbers / Spare parts

Short designation	Article number
Aspirating Smoke Detector ASD 531	11-2000002-01-XX
Replacement smoke sensor SSD 31	11-2200009-01-XX
eXtended Line Module XLM 35	11-2200003-01-XX
RIM 36 Relay Interface Module	11-2200005-01-XX
SD memory card (industrial version)	11-4000007-01-XX
AMB 31 Main Board	11-2200012-01-XX
Aspirating Fan Unit AFU 32, complete	11-2200008-01-XX
Air Flow Sensor AFS 32	11-2200007-01-XX
Insect Protection Screen IPS 35 (set of 2)	11-2300012-01-XX
Lithium battery	11-4000002-01-XX
Cable screw union M20 (set of 10)	11-4000003-01-XX
Cable screw union M25 (set of 10)	11-4000004-01-XX
UMS 35 Universal Module Support	4301252.0101
Technical description ASD 531	T 140 416
Material for the sampling pipe	T 131 194
Commissioning protocol	T 140 418
Data sheets	XLM 35 T 140 088
	RIM 36 T 140 364
AFU 32 installation instructions	T 140 426

Dimensioned drawing

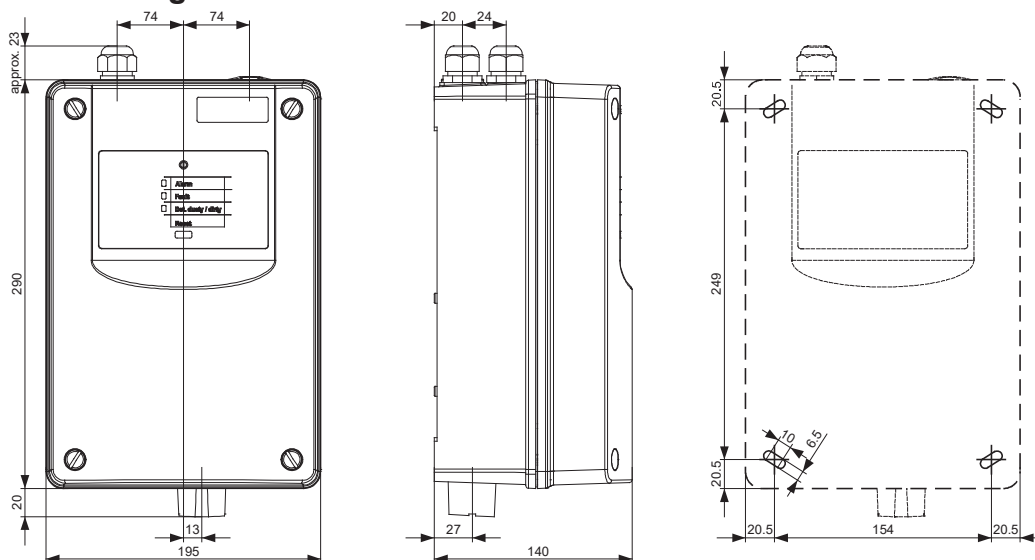

Fig. 5 Detector housing dimensioned drawing

Technical data

Type	SEC-ASD 531		
Supply voltage range	14 to 30		VDC
Maximum power consumption, measured at →	typical		
	14 VDC ①	24 VDC	
SEC-ASD 531	Quiescent / fault	approx. 110	approx. 75 mA
	Alarm	approx. 120	approx. 80 mA
	additionally with RIM 36	approx. 30	approx. 15 mA
	additionally with XLM 35	approx. 15	approx. 5 mA
Switch-on current peak ② (caused by EMC protection elements on the ASD supply input)	approx. 5		A
	for max. 1		ms
Sampling pipe length	see T 140 416, Sec. 4.2.1		
Sampling pipe diameter, typical (inner/outer)	Ø 20 / 25 mm		
Max. number of sampling holes	see T 140 416, Sec. 4.2.1		
Sampling hole diameter	Ø 2 / 2.5 / 3 / 3.5 / 4 / 4.5 / 5 / 5.5 / 6 / 6.5 / 7 mm		
Response range	EN 54-20, Class A, B, C		
Protection type compliant with IEC 529 / EN 60529 (1991)	54		IP
Ambient conditions compliant with IEC 721-3-3 / EN 60721-3-3 (1995)	3K5 / 3Z1		class
Extended ambient conditions:			
• Detector housing temperature range	-10 – +55		°C
• Sampling pipe temperature range	-10 – +55 ③		°C
• Max. permissible temperature fluctuation in detector housing and sampling pipe operation	20 ③		°C
• Max. permissible storage temperature for detector housing (without condensation)	-20 – +70		°C
• Ambient pressure difference between detector housing and sampling pipe (sampling holes)	must be identical		
• Humidity ambient condition for detector housing (transient without condensation)	95 ③		% rel. h
• Humidity ambient condition (continuous)	70 ③		% rel. h
Max. loading capacity, relay contact	50		VDC
	1		A
	30		W
Max. loading capacity per OC output (dielectric strength 30 VDC)	50		mA
Plug-in terminals	2.5 mm ²		
Cable entry for cable Ø	Ø 5 – 12 (M20) / Ø 9 – 18 (M25) mm		
Noise level	min.	24.5 dB (A)	
	max.	27.0 dB (A)	
Housing	material	ABS blend, UL 94-V0	
	colour	grey 280 70 05 / anthracite violet 300 20 05 RAL	
Approvals	EN 54-20		
SEC-ASD 531 dimensions (W x H x D, without/with packaging)	195 x 333 x 140 / 215 x 355 x 160		mm
Weight SEC-ASD 531 (without/with packaging)	1,950 / 2,250		g



- ① Power consumption at maximum permitted voltage drop in the electrical installation (decisive value for calculating the conductor cross-section).
- ② May cause the protective circuit to trigger immediately in the case of power supplies with overload protective circuits (primarily in devices with no emergency power supply and output current of < 1.5 A).
- ③ Lower or higher temperature ranges are also possible subject to consultation with the manufacturer. The manufacturer must be consulted if the device is used in the condensation range.